

CHRYSLER

Camshaft Sprocket Service for 1994 2.0L DOHC Engines

The camshaft sprockets on the 2.0L DOHC engines built Aug. 1, 1994 through Oct. 31, 1994 may have two timing marks on the 2.0L side of each sprocket (see **Figure 1**, below).

Engine damage may result from incorrect installation of either camshaft sprocket after an engine repair.

It is important that the correct timing mark is used when setting the cam timing. If the wrong timing mark is used, the valves may come into contact with the pistons resulting in engine damage.

The engine build date code is located on the right rear area of the valve cover.

Intermittent Valve Train Ticking Noise on Hot Or Cold 1990 3.0L Engines

Some 1990 3.0L engines built before engine code 7-370 may exhibit a valve train ticking noise. This noise can occur when the engine is cold and/or at operating temperature. This condition may be the result of a rocker arm casting burr in the area of the rocker arm shaft bore.

With the engine running, use a stethoscope to pinpoint the noise location by listening at the right and left (front and rear) cylinder head covers. Turn the engine off, and remove the appropriate cylinder head cover. Carefully move the rocker arms, one at a time, away from the cam shaft bearing cap. Inspect the rocker arm surface that contacts the cam shaft bearing cap for cast-

ing burrs as shown in **Figure 2**, below. If casting burrs are found, perform the repair procedure listed below.

The engine must be rotated to allow the valves in the open position to close before the rocker arm can be moved for inspection.

If no casting burrs are found, perform the valve lash adjuster noise diagnosis as outlined in the appropriate Service Manual.

Repair Procedure:

This repair involves the removal of the rocker arm assembly, removal of the rocker arms from the shaft and removing the casting burr from the rocker arm(s).

To prevent damaging the camshaft seal, camshaft bearing surfaces or camshaft jumping time the following camshaft hold down tool should be fabricated and positioned on the rear of the camshaft before removing the rocker assembly.

Parts Required to Fabricate Camshaft Hold Down Tool:

1) 5/16" x 2 1/2" bolt, 1/2" flat washer tie strap, M8 X 35 mm bolt.

Carefully grind down the circumference at the end of the 5/16" bolt until it fits snugly in the hole at the rear of the camshaft.

2) Install the 1/2" washer on the bolt and install the bolt in the hole in the rear of the camshaft. Feed the tie strap through the washer and attach to the engine as follows: Front (left) cylinder head, route strap around exhaust pipe and pull strap tight (**Figure 3**, below).

Rear (right) cylinder head, install the M8 bolt on rear of the block, route strap around the bolt and pull strap tight (**Figure 4**, below).

1) Remove and disassemble the rocker arm assembly as outlined in the appropriate Service Manual.

2) Using an oilstone or 500 wet/dry sand-

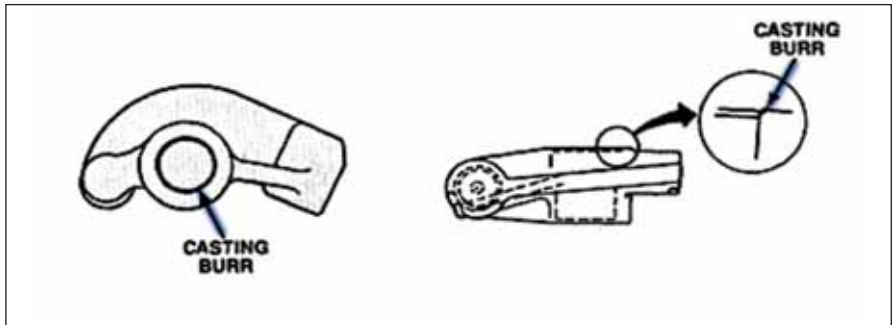

Figure 2 Inspect the rocker arm surface that contacts the cam shaft bearing cap for casting burrs. If casting burrs are found, perform the repair procedure.

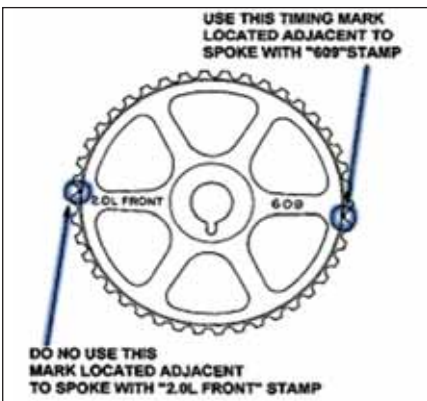

Figure 1 1994 2.0L engines may have two timing marks on the 2.0L side of each sprocket.

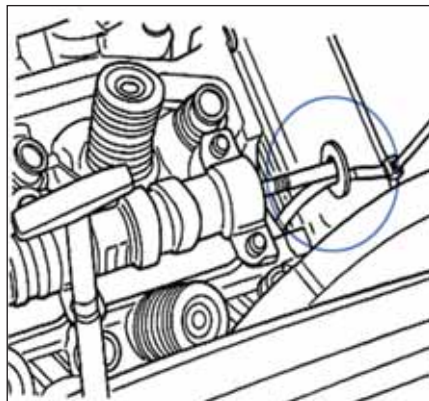

Figure 3 Feed the tie strap through the washer and attach to the engine.

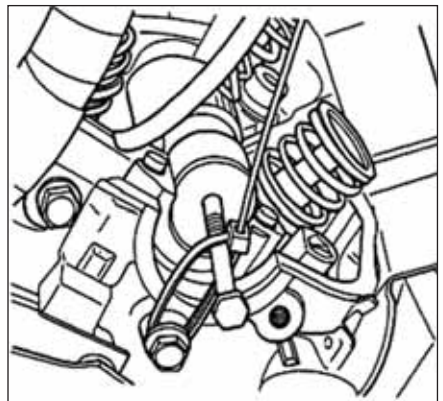

Figure 4 Install the M8 bolt on rear of the block, route strap around the bolt and pull strap tight.



Engine & Performance Warehouse

Qty.	Spark Knock Fix Part Number	Description	Standard - Non Spark Knock Part No.
AR (1)	68003592AA	2004 RS 3.3L	04748363AD thru AH
AR (1)	68003593AA	2005 RS (early) 3.3L	04748533AD thru AG
AR (1)	68003596AA	2005 RS (early) 3.3L SNG	04748535AD thru AG
AR (1)	68003597AA	2005 RS (normal) 3.3L	04748631AA thru AG
AR (1)	68003599AA	2005 RS (normal) 3.3L SNG	04748633AA thru AG
AR (1)	68003603AA	2006 RS 3.3L 50 State or Federal	05094656AD
AR (1)	68003606AA	2006 RS 3.3L SNG 50 State or Federal	05094657AD
AR (1)	68003608AA	2006 RS 3.3L California	05187756AA
AR (1)	68003609AA	2006 RS 3.3L SNG California	05187757AA

Figure 5 Table of PCM part numbers to repair spark knock on affected 3.3L engines.

paper soaked in oil, remove the casting burr from the rocker arm. The rocker arm surface should be smooth and free of burrs.

3) Thoroughly clean the rocker arm to remove all traces of the abrasive material.

4) Clean the rocker arms and rocker shafts and reassemble as outlined in the appropriate Service Manual.

5) Install the rocker arm assembly.

6) Tighten the rocker arm bearing cap bolts to 85 in.lbs. (10 Nm) torque in the sequence outlined in the appropriate Service Manual.

7) Remove the camshaft hold down tool.

8) Install the cylinder head cover.

Engine Spark Knock On 2004-'06 3.3L Engines

This bulletin involves replacing the Powertrain Control Module (PCM) on some 2004-2006 vehicles equipped with a 3.3L engine.

Some affected engines produce an audible spark knock under heavy acceleration, most prevalent in ambient temperatures above 80°F.

Using the Diagnostic Scan Tool (DRB III®) with the appropriate Diagnostic Procedures Manual, verify all engine systems are functioning as designed. If DTCs are present, record them and repair as necessary before proceeding further.

Thorough and complete diagnosis must be performed on the vehicle and all

other sources of mechanical noise must be ruled out and/or corrected before considering a PCM replacement.

CAUTION: Installation of the listed PCM's on vehicles that do not exhibit audible spark knock may affect engine performance and/or fuel economy.

Parts Required:

(See Figure 5)

Special Tools/Equipment:

- CH6000A Scan Tool (DRBIII)
- CH7000A/7001A J1962 Cable with red DRBIII connector

Repair Procedure:

1) Using the Diagnostic Scan Tool (DRB III) ID the PCM on the vehicle to determine the current part number. Using the parts table shown in Figure 5, determine the correct "Spark Knock Fix Part Number" based on the current (standard) PCM part number found.

2) Replace the PCM with the correct "Spark Knock Fix" PCM. Refer to the detailed service information.

NOTE: The replacement PCM is already programmed with the appropriate software. DO NOT flash reprogram the replacement PCM.

3) Transfer the mileage and the VIN to the replacement PCM.

Stuck Oil Pressure Relief Valve on 2001-2002 3.3L and 3.8L Engines

This bulletin supersedes technical service bulletin 09-007-01 dated August 31,



Engine Kits & Performance Parts!

800-888-8970
www.epwi.net

ALBUQUERQUE
(877) 767-0100
(505) 761-0100

OAKLAND
(800) 234-1410
(510) 569-9802

ANAHEIM
(800) 634-0969
(714) 634-3803

OKLAHOMA CITY
(800) 937-3652
(405) 942-8435

ANCHORAGE
(800) 288-5573
(907) 563-7278

PHOENIX
(888) 272-0191
(602) 272-0191

DALLAS
(800) 284-5348
(214) 637-3301

PORTLAND
(800) 876-5152
(503) 232-2270

DENVER
(800) 888-8970
(303) 572-8844

SAN ANTONIO
(800) 423-2707
(210) 224-8424

HOUSTON
(800) 288-6548
(713) 862-2929

TACOMA
(800) 876-5152

Circle 107 in Feb. Engine Builder for more info

CHRYSLER

2001, which should be removed from your files. All revisions are highlighted with (**) and include an additional model year.

NOTE: this bulletin applies to vehicles **built prior to January 1, 2002** equipped with a 3.3L or 3.8L engine.

There have been reported incidents of stuck oil pressure relief valve assemblies in the chain case cover. With a stuck oil pressure relief valve, the oil pressure is not regulated as it is supposed to be, resulting in possible low oil pressure and engine damage due to oil starvation.

When a short block engine is replaced, replace the chain case cover assembly if any of the following symptoms are present:

- The vehicle exhibited low or no oil

pressure at idle;

- There is metal debris in the oil pan upon removal from engine;
- Main or rod bearing(s) are spun;
- Crankshaft rod or main journals are scored; and
- Intermittent oil light flashing off and on.

The purpose of replacing the chain case cover is to prevent damage to a second engine due to a stuck oil pressure relief valve. Before the oil filter adapter is reattached to the new short block, verify that oil feed and return passages are clear of debris that may hinder oil flow or re-enter the oil pressure relief valve on the new engine.

Parts Required:

1 - Timing Chain Case Cover, p/n 05019333AA.

Chrysler 3.7L Throttle Body 'Whistle-Like Sounds'

Whistling sounds have been reported coming from some 2007 Chrysler 3.7L engines. The intake-to-throttle-body joint may be the cause of the "whistle-like" sound.

This repair procedure involves applying a thin bead of RTV to the intake manifold-to-throttle body joint. This information applies to vehicles equipped with a 3.7L engine built on or before March 12, 2007.

There have been reports of vehicle owners who experience a slight "high frequency (pitch)" whistle-like sound while driving. This sound is not loud and may not be noticeable to most drivers. The sound can occur at any ambient or engine operating temperature. The whistle-like sound is most noticeable under load, with a light throttle, and between 1,200 and 2,000 rpms. Please note, very few vehicles will exhibit this condition.

If the customer experiences the above condition perform the following repair procedure.

1) Remove the Electronic Throttle Control (ETC) throttle body from the

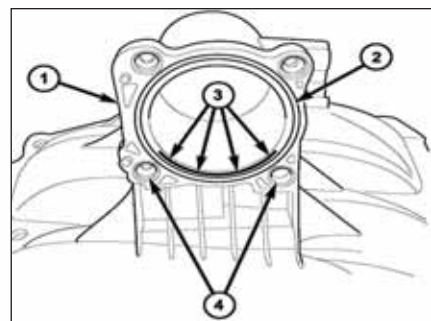

Figure 6 Apply RTV to the lower section of the joint between the lower two throttle body bolt attachment holes.

intake manifold.

2) Apply a very small diameter bead (1 mm) of RTV to the intake manifold-to-throttle body joint. The RTV is to be applied to the lower section of the joint between the lower two throttle body bolt attachment holes (**Figure 6**, page

We Can Do Any Ring Size!

1.75" to over 10" Bores



Sign up today at Hastingsmfg.com for a FREE Tough Guy Racing Rings Wall Chart and New Applications e-Newsletter.



800-776-1088
hastingsmfg.com
sales@hastingsmfg.com

Circle 108 in February Engine Builder for more information

CHRYSLER

8). A very small amount of RTV is needed to seal the slight space/gap on the inner surface of the joint. The gap was created by a slight taper in the intake manifold joint surface. Do not apply an excessive amount of RTV to the joint. And do not over-torque the throttle body bolts, as it may cause damage to the throttle body.



Figure 7 Coolant rolls across the front of the pump and behind the pulley, making it appear to leak from the weep hole.

3) Install the ETC throttle body to the intake manifold. Tighten the throttle body's four attaching bolts to 60 in.lbs. (7 Nm). Wipe off inside joint of any excess RTV that is squeezed out.

4) Reassemble the remaining engine components.

Coolant Leak Leads to Unnecessary Pump Replacement on 1993-2003 3.9L V6, 5.2L & 5.9L Engines

A coolant leak from a source above the water pump or from an improperly installed bypass tube on the water pump itself will cause coolant to pool on top of the timing cover. This coolant then rolls across the front of the pump and behind the pulley, making the pump appear to leak from the weep hole (**Figure 7**, above). This often results in unnecessary pump replacement.

The pulley on this pump completely covers the face of the pump, making the correct diagnosis difficult (**Figure 8**, above). The bypass tube that is shipped loose in the box is often installed without sealant or is not tightened properly. The subsequent leak can cause antifreeze to gather on top of the timing cover, which is difficult to see. There are other components above the water pump, including the thermostat housing and the bypass hose, that can leak and cause antifreeze to gather in the same place and eventually mimic a leaking water pump.

When replacing this pump, the supplied bypass tube should be installed with thread sealant and should be prop-

erly tightened before installation of the pump. The bypass hose and clamp should be inspected for wear, holes or other flaws before they are reused and the area should be inspected for evidence of



Figure 8 The pulley completely covers the face of the pump, making the correct diagnosis difficult.

other leaks, such as from the thermostat housing. The original leak that prompted the pump to be changed may still be present and will need to be addressed.

— From ASC Industries, Inc. **TSG**



MAHLE pistons are OE quality and have many premium OE features.

- **Compensated Ring Grooves** - Assure proper ring loading and oil control.
- **Expansion Controlled Design** - With the tighter fitting clearances comes reduced engine noise, reduced wear; reduced emissions and improved oil control in the long term.
- **Pin Offset** - For reduced engine noise.
- **Lightweight Design** - For reducing reciprocating mass without sacrificing reliability. This reduces bearing loads, offers smoother engine running and improves engine response.